

Terahertz Transmission, Emission, and Detection with Horizontally-Aligned Single-Walled Carbon Nanotube Films

K. A. D. Davis,¹ L. G. Booshehri,¹ J. Kono,¹ K. Takeya,² D. S. Rana,² M. Tonouchi,² C. L. Pint,³ R. H. Hauge,³ and J. Liu⁴

1. Department of Electrical Engineering and the NanoJapan Program, Rice University
2. Institute of Laser Engineering, Osaka University,
3. Department of Chemistry, Rice University
4. Department of Chemistry, Duke University

Terahertz (THz) radiation has a number of unique properties that make it ideal for various applications, from the medical world to restoring damaged art. Since it lies in a technologically undeveloped frequency range (too high for electronics and too low for photonics), much research is currently underway worldwide to find new methods for producing it, detecting it, and using it. Recent theoretical studies have proposed the use of single-walled carbon nanotubes (SWNTs) both in THz generation and detection by utilizing their superior electrical conduction properties, but no experimental demonstrations have been reported. The goal of our project was to determine if it would be possible to produce THz radiation from horizontally oriented SWNTs on a crystalline substrate. To determine this we analyzed seven samples of horizontally oriented nanotubes: three were on c-plane sapphire and four on z-cut quartz. They were prepared by growing the nanotubes vertically out of the substrate, then laying them flat on the substrate to create a patchwork of horizontal nanotubes and open spaces. The samples were made at Rice University and Duke University and then tested at Osaka University. We first performed time-domain THz spectroscopy (TDTS) on them to determine some of the basic properties of the nanotube films, such as the refractive index and extinction coefficient in the THz range. To do this we used a DAST crystal to emit an extremely broadband THz signal on the order of 7 THz. After obtaining this data, we performed THz emission tests to determine the ability of the samples to emit THz radiation. This required the addition of electrical contacts to the samples.

Terahertz Transmission, Emission, and Detection with Horizontally-Aligned Single-Walled Carbon Nanotube Films

K. A. D. Davis,¹ L. G. Booshehri,¹ J. Kono,¹ K. Takeya,² D. S. Rana,² M. Tonouchi,² C. L. Pint,³ R. H. Hauge,³ and J. Liu⁴

1. Department of Electrical Engineering and the NanoJapan Program, Rice University

2. Institute of Laser Engineering, Osaka University,

3. Department of Chemistry, Rice University

4. Department of Chemistry, Duke University

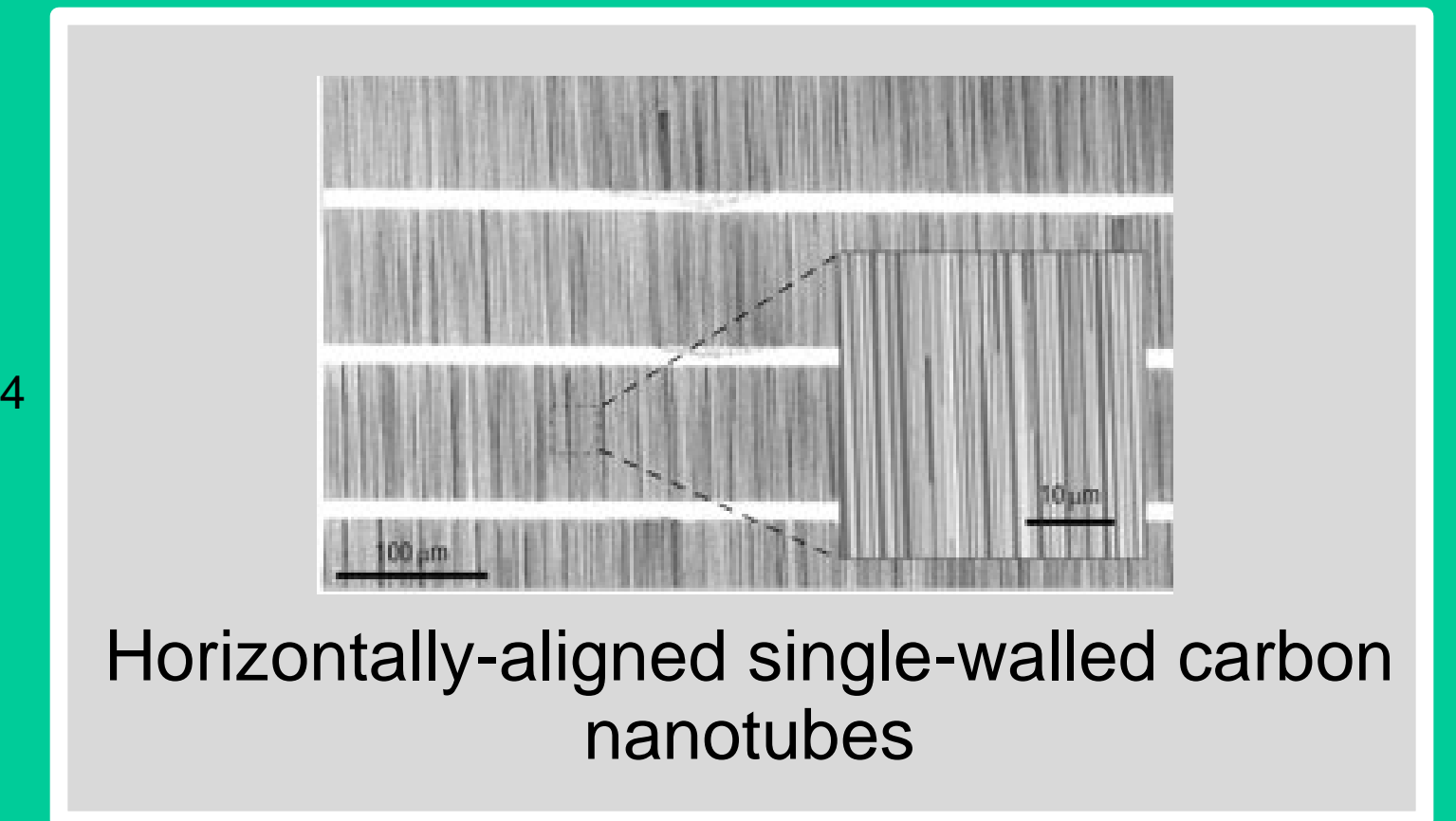

Introduction

- For a Single-Walled Carbon Nanotube (SWNT), electrical properties are dependent on the physical structure of the nanotubes.

- They can be either metallic or semi-conductive in nature.

- Recent theoretical studies have proposed the use of single-walled carbon nanotubes (SWNTs) both in THz generation and detection

- Is it would be possible to produce THz radiation from horizontally oriented SWNTs on a crystalline substrate.

Nanotube Structures

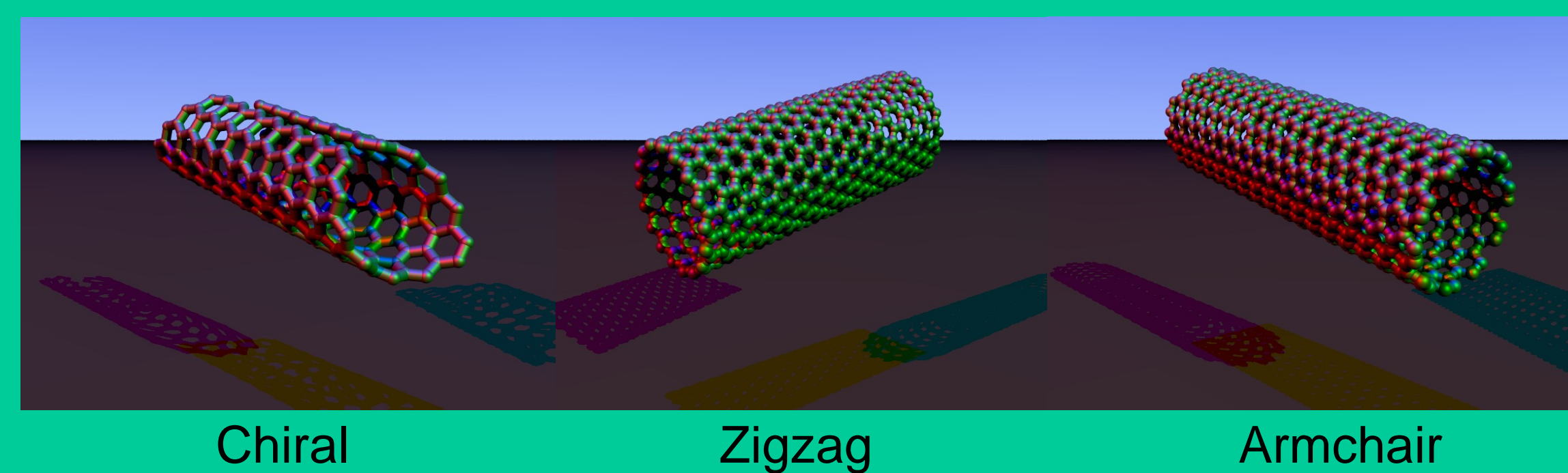

Terahertz Radiation

- technologically undeveloped frequency range

- research is underway worldwide to find new methods for producing it, detecting it, and using it.

- Possible applications include: information and communications technology; biology and medicine; non-destructive evaluation; homeland security; quality control; environmental monitoring; and ultrafast computing.

THE ELECTROMAGNETIC SPECTRUM

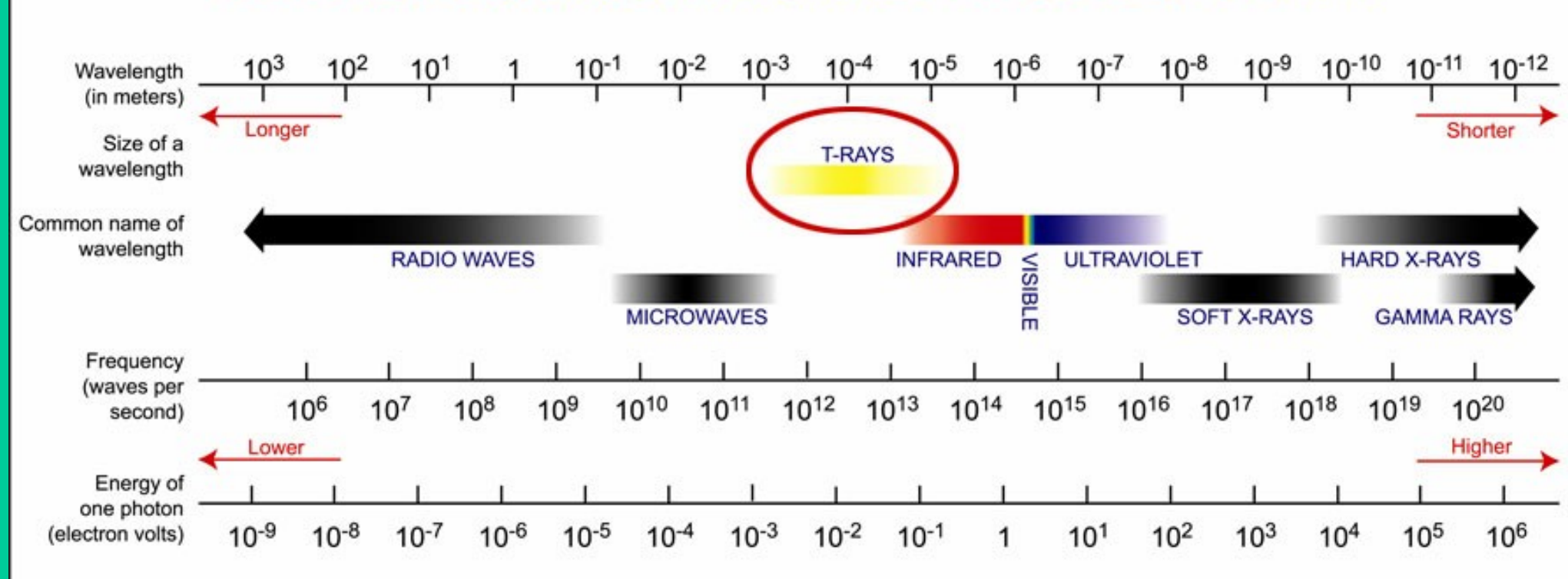

Results

Electric Field

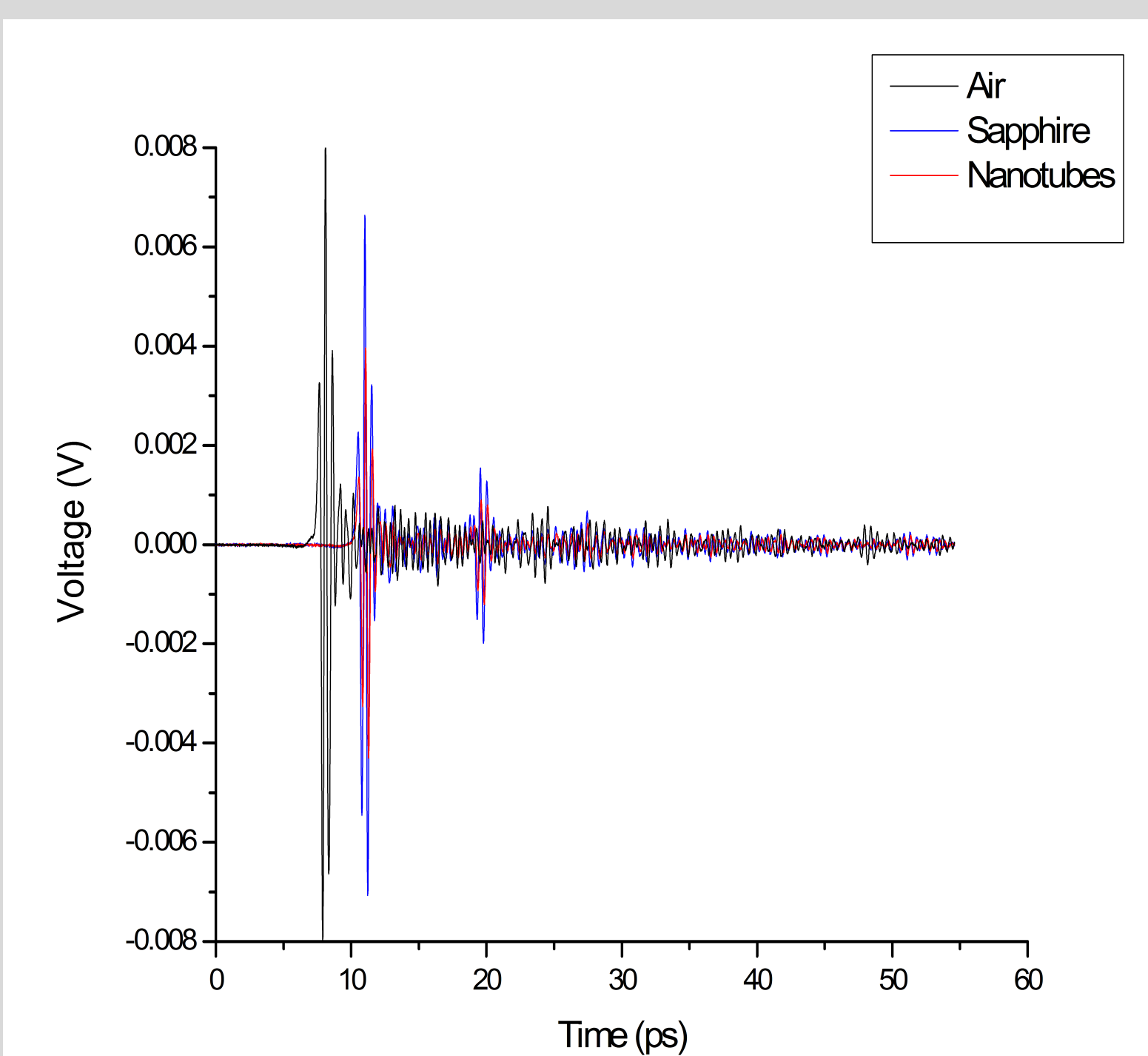

Transmittance

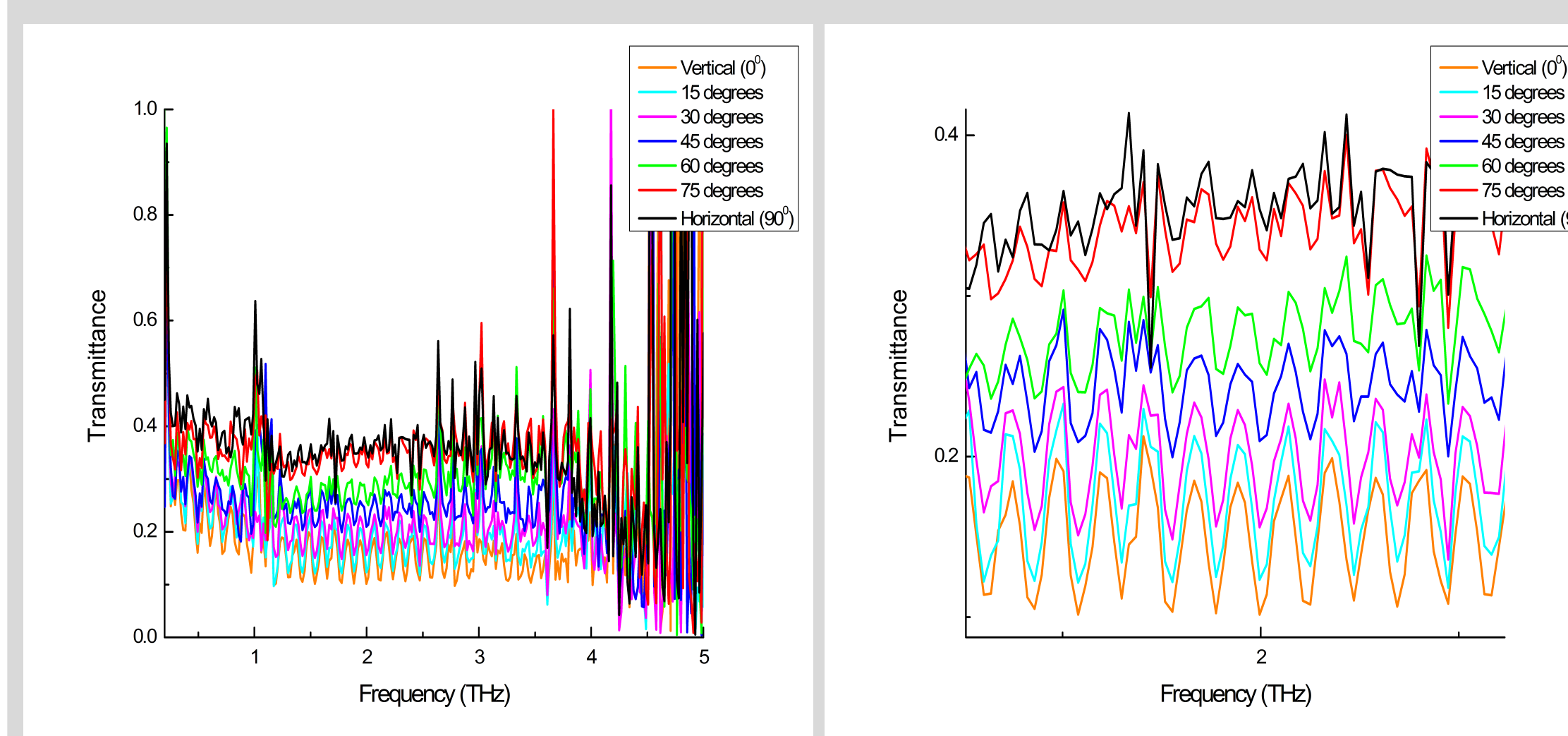

Imaginary Part of Complex Refractive Spectra (k)

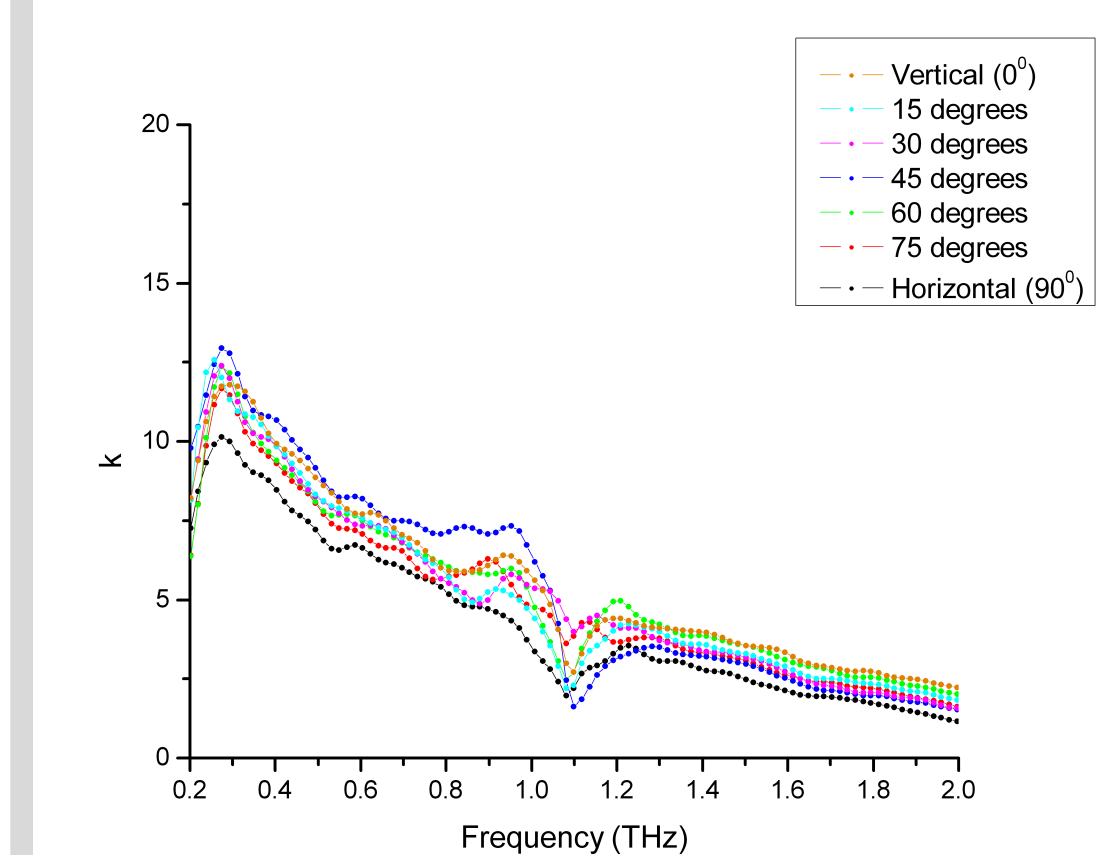

Real Part of Complex Refractive Spectra (n)

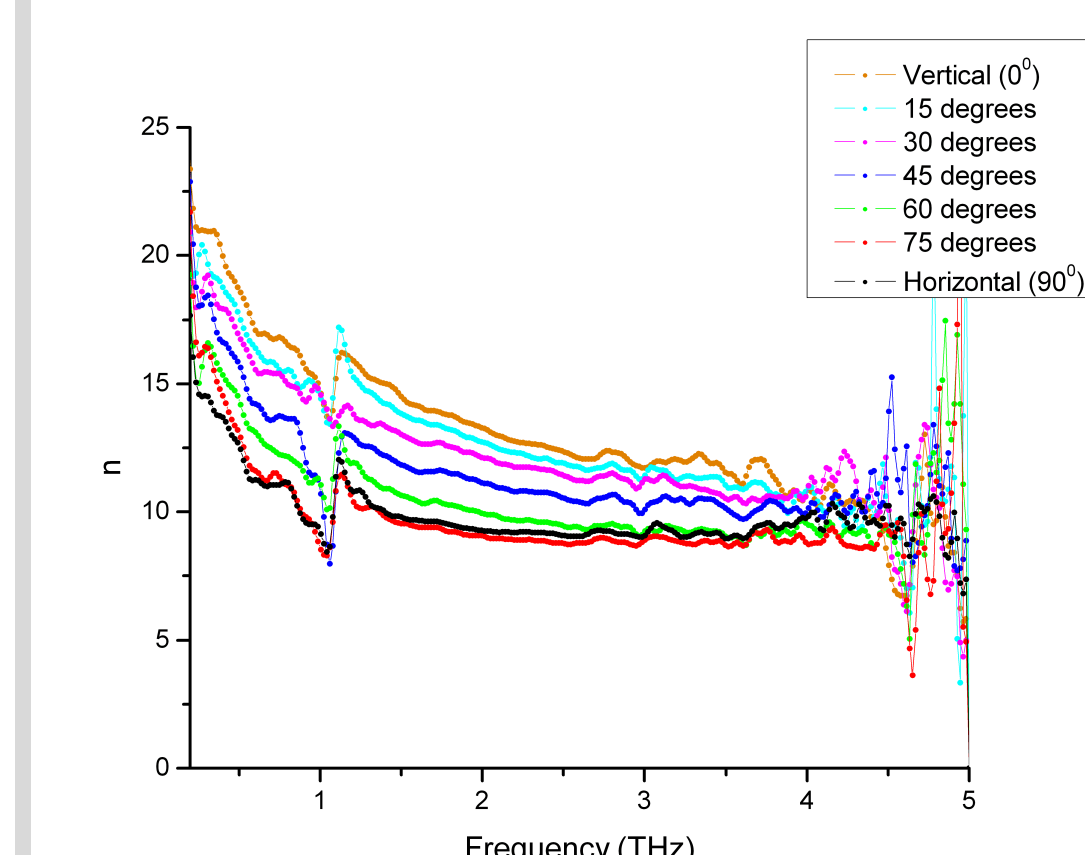

Terahertz Time Delay Spectroscopy System (TDS System)

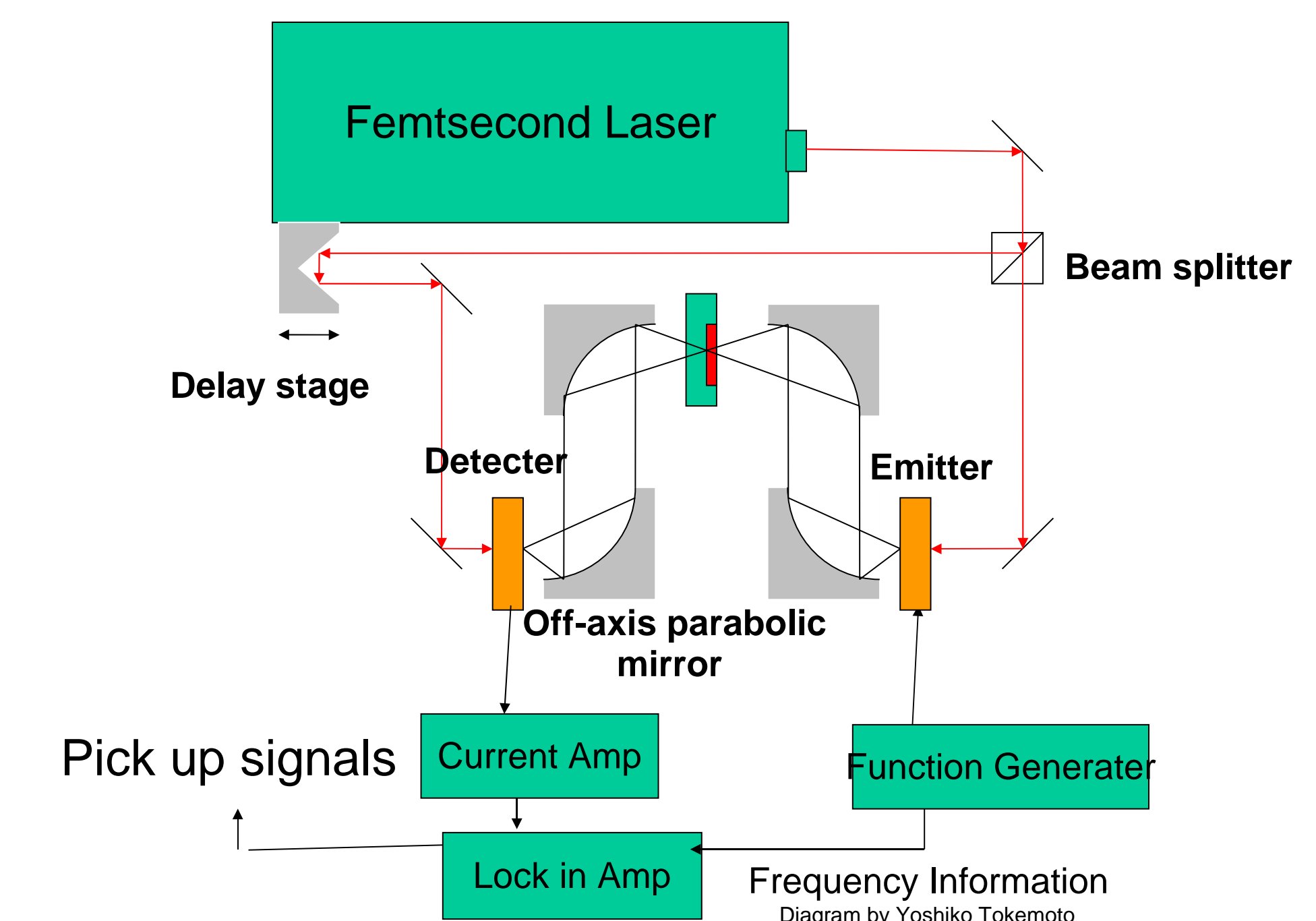

Conclusion and Future Plans

- Our samples exhibited clear polarization anisotropy

- Determined n and k.

- Terahertz emission is definitely possible with Carbon nanotubes

- Thicker films are most likely necessary.

- Contacts must be added to the substrate before the films

- If possible, testing of pure metallic and pure semiconductor films

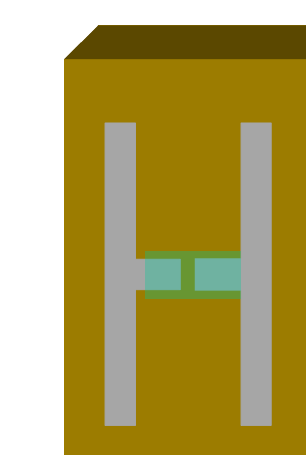

Example of sample with electrical contacts. The contacts are applied first, then the film.